

# High fidelity superconducting qubit control at millikelvin temperatures

**Siqi Li**

Kuang Liu, Zhiyuan Wang, Zhirong Lin

Shanghai Institute of Microsystem and Information Technology, Chinese Academy of Sciences (CAS), 865 Changning Road, Shanghai, China

lsq@mail.sim.ac.cn

## Abstract

Scaling superconducting quantum processors to fault-tolerant regimes is increasingly constrained by wiring complexity, operational overhead, and the heat-load bottleneck arising from room-temperature microwave control schemes [1]. A superconducting circuit based on single-flux-quantum (SFQ) logic is an attractive alternative due to its high speed, low power dissipation, and cryogenic nature [2]. Here, we report a SFQ-based qubit-control chip that interfaces with transmon qubits via a cryogenic RF link [3, 4]. We observe coherent SFQ-driven qubit dynamics and calibrate a complete single-qubit Clifford gate set. Randomized benchmarking yields an average Clifford fidelity of 99.9% with consistently high gate fidelities, validating the proposed SFQ-based approach as a high-fidelity and scalable solution to the control challenges in superconducting quantum systems.

## References

- [1] Franke, D.P., et al., *Microprocessors and Microsystems* (2019) **67** 1-7
- [2] Holmes, D. S. & Hamilton, B. A., *Proc. IEEE International Roadmap for Devices and Systems* (2022)
- [3] Liu, K., et al., *Phys. Rev. B* (2023) **108** 064512
- [4] Liu, K., et al., *Chinese Physics B* (2023) **32**(12)

## Figures

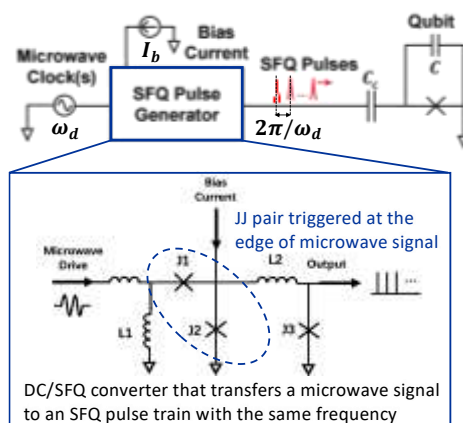

**Figure 1:** Qubit control based on single-flux-quantum logic superconducting circuit

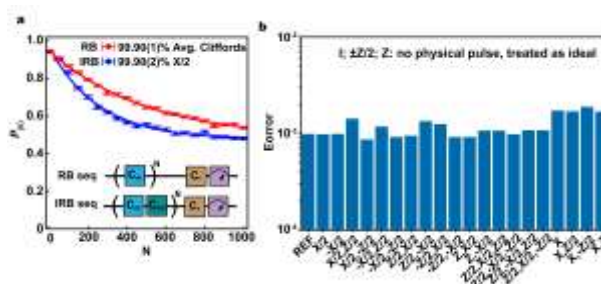

**Figure 2:** Randomized benchmarking (RB) and interleaved RB assessment (a) Average gate fidelity (b) Individual gate fidelity